

FLAMEPROOF MINING ENCLOSURES



➤ Description:

Enclosures type OT and TSV are constructed in flame-proof protection on demand of standards IEC 79.1 and EN 50018. Constructions also correspond the recommendations of IEC 79 and most of national standards in the field of explosion protection, such as VDE 0170/0171, TGL 19491...503, NFC 12-320;BS, GOST and others. Enclosure OT and TSV can be used independently or they can be constructed in distribution battery. Cabinets type PVO or PV to connect the enclosures into distribution battery in which the explosion protection busbars are built in.

➤ Mechanical realisation:

Flame proof enclosures type OT and TSV are made of steel plate. All enclosure metallic parts are painted with basic colour and twice with surface colour. Enclosure and cover form flame-proof Exd-(box) according to IEC 79,1 and EN 50018.

Therefore the opening system covering is made in this way, that the covering can't opened in case when the main switch is not off. Accessible parts will be at opened enclosure always in power-off (disconnected) condition.

The cover can be opened when the main switch is in position 0-disconnected. In this case the covering screw can be unscrewed with appropriate spanner (key, a triangular spanner). In this way the opening is possible. The cover is casted from grey cast. A small window made of harding glass and resistant to increased pressure or the button axis for different purposes (control...) can be placed on it.

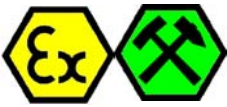

➤ Connection cabinets:

Two types of connecting cabinets, which can be placed on conducting side of enclosure are worked out for housing type OT and TSV. They are worked out on explosion protection-increased safety Exe, with mechanical protection IP 54.

The power supply and conductor into the housing of flame proof enclosure is carried out over bushings, which are placed in connection cabinets.

A transparent window fi 56 mm can be built in.

➤ Electric realization:

Elements of electric equipment are built in on supporting plate, which is fixed in housing. The withdrawable rack units contain all necessary electric equipment. Connectible realizations of supporting plates can be simply and quickly replaced. According to the purpose of equipment which is built-in enclosures the following basic realizations can be distinguished:

OT-1 MK 500 insulation monitoring

OT-B, TSV-B enclosure with main switch and fuses

OT-OS, TSV-OS circuit breakers with overload and short circuit protection and with electronic units

OT-Tr, TSV-Tr transformer for lighting with electronic units

OT-Emx, TSV-ExM there are functional various electronic moduls on user demands built in housing.

TSV-MS;

TSV-LD;

TSV-DA;

motor protection switches with main switch, fuses, contactor and protective overload relay..

switch control on the housing or remote control

control voltage 42 V

MS – motor protective switch. Direct on line

LD – motor protective switch. Direct on line, left-right

ZT – motor protective switch. Star-triangle

DA – motor protective switch for multi speed motors

➤ Explosion protection :

Enclosure explosion protection is flame proof according to IEC 79.1 and EN 50018 with connection cabinets and busbars cabinets there is increased safety according to IEC 79-7 and EN 50019.

➤ Dimensions of OT-1

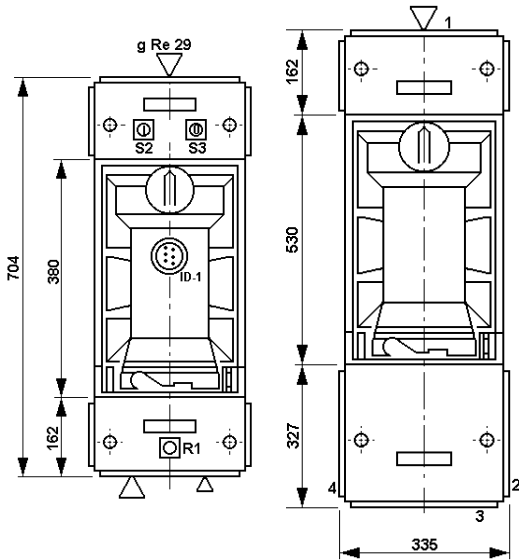

➤ Dimensions of OT-2

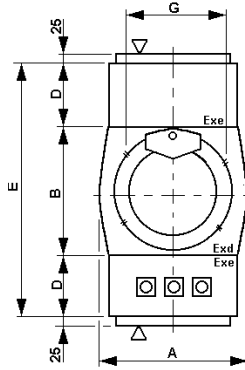

➤ Dimensions of TSV

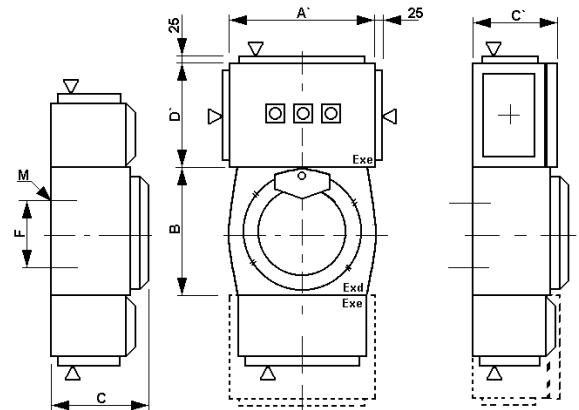

➤ Type	A'	B	C	C'	D	D'	E	F	G	M	
TSV-1	230	315	240	230	210	110	315	460	110	160	M 8 - 16
TSV-2	360	365	370	360	210	135	315	640	110	230	M 8 - 16
TSV-3	480	485	625	480	210	150	315	925	454	340	M 10 -20

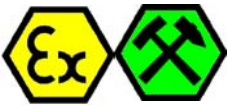

Dimensions:

Dimensions for different types of enclosures are in table 1. When making the project, it is necessary to take into account also the cable glands. An example of distribution battery is shown in picture 2. To connection housings TSV in distribution battery, the boxes PV with Exe terminals are used.

Electronic units for insulation monitors:

Electronic units are made for use in IT network. (IT system). Construction, measured current and measured voltage are in all electronic units according to standards IEC 79—11 for intrinsic safety circuits.

Electronic protected units are built in OT enclosures Exd

Technical data:

- rated voltage: 500 V, 50 Hz
- rated current: 320 A or 550 A
- dynamic short circuit current: 20 kA for In=320 A and 30 kA for In=550 A
- explosion protection; Exde I, for mining industry
- mechanical protection: IP 54

- **ZZS-500A** -earth fault monitoring relay
- **NZKT-1** -protective conductor monitoring relay
- **IZS-42** -control voltage insulation monitoring relay
- **NIMR-220/2** -lighting network insulation monitoring relay
- **KPC-1** -monitoring relay for submersible pumps

Example of distribution battery with enclosures type - OT

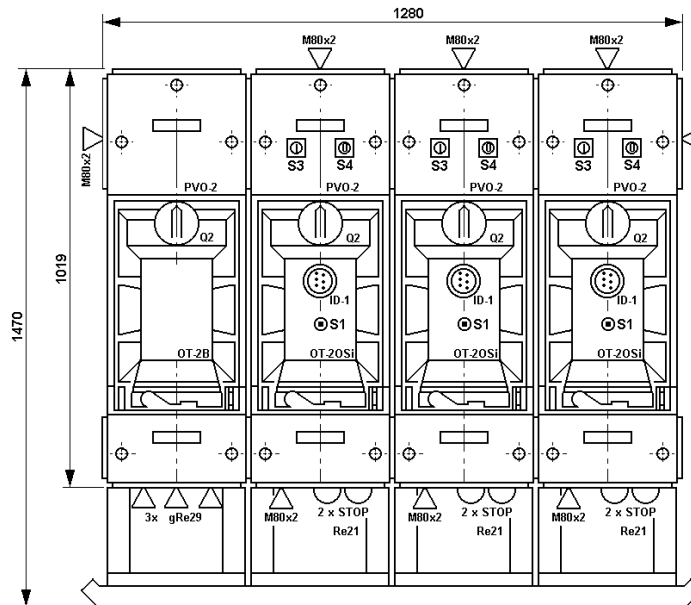

Example of distribution battery with enclosures type - TSV

